

DEFENDER SERIES[®] OVERFILL PREVENTION VALVE

INSTALLATION GUIDE

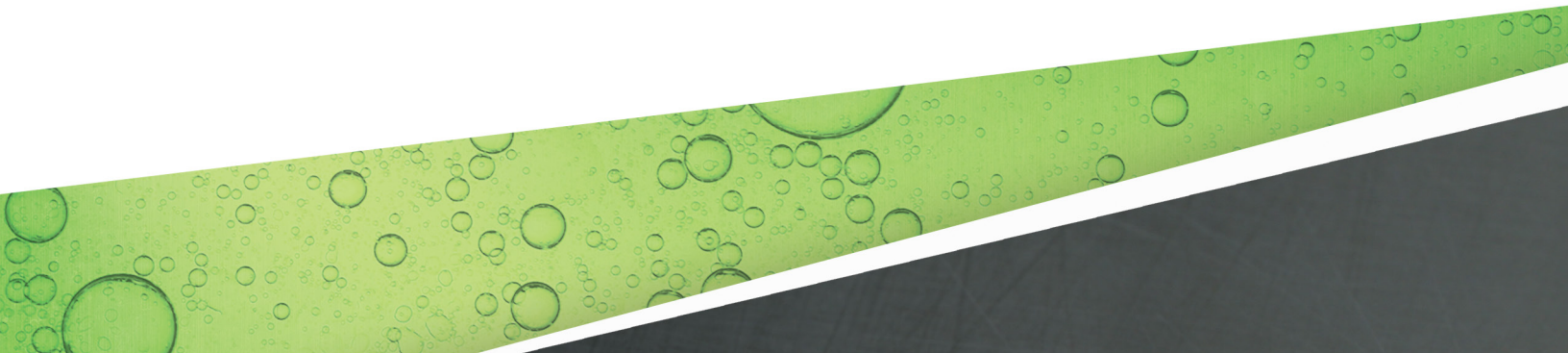

The information in this publication is provided for reference only. While every effort has been made to ensure the reliability and accuracy of the information contained in this manual at the time of printing, we recommend that you refer to “franklinfueling.com” for the most current version of this manual. All product specifications, as well as the information contained in this publication, are subject to change without notice. Franklin Fueling Systems does not assume responsibility and expressly disclaims liability for loss, damage, or expense arising out of, or in any way connected with, installation, operation, use, or maintenance by using this manual. Franklin Fueling Systems assumes no responsibility for any infringement of patents or other rights of third parties that may result from use of this manual or the products. We make no warranty of any kind with regard to this material, including, but not limited to, the implied warranties of merchantability and fitness for a particular purpose.

Copyright © 2018 Franklin Fueling Systems, Madison, WI 53718. All world rights reserved. No part of this publication may be stored in a retrieval system, transmitted, or reproduced in any way, including, but not limited to, photocopy, photograph, magnetic, or other record, without the prior written permission of Franklin Fueling Systems.

For technical assistance, please contact:

Franklin Fueling Systems
3760 Marsh Rd.
Madison, WI 53718
USA

Web: franklinfueling.com

Telephone:

USA and Canada: +1.608.838.8786, +1.800.225.9787

USA and Canada Technical Support: +1.800.984.6266

UK: +44 (0) 1473.243300

Mexico: 001.800.738.7610

China: +86.10.8565.4566

Defender Series is a registered trademark of Franklin Electric Company, Inc.

F-9044 r7

Contents

- Introduction1
- Specifications1
- Questions and concerns1
- Conventions used in this manual1
- Operating precautions2
- Primary shutoff3
- Installation.....5
- Installing the OPV.....5
- Required equipment.....5
- Determine drop tube lengths6
- Mark and cut the drop tubes8
- Install the upper drop tube adapter9
- Complete the installation11
- Operational inspection12
- Maintenance15
- Inspect and verify the final shutoff level16
- Dimension drawing18
- Certification information18
- Production specifications18
- OPV installation record sheet19

Intentionally Blank

Introduction

Questions and concerns

In case of emergency, follow the procedures established by your facility. If you have questions or concerns about safety or need assistance, use the information below to contact Franklin Fueling Systems:

Web: franklinfueling.com

Telephone:

USA and Canada: +1.608.838.8786, +1.800.225.9787

USA Technical Support: 1.800.984.6266

UK: +44 (0) 1473.243300

Mexico: 001.800.738.7610

China: +86.10.8565.4566

Conventions used in this manual

This manual includes safety precautions and other important information presented in the following format:

NOTE: This provides helpful supplementary information.

IMPORTANT: This provides instructions to avoid damaging hardware or a potential hazard to the environment, for example: fuel leakage from equipment that could harm the environment.

⚠ CAUTION: This indicates a potentially hazardous situation that could result in minor or moderate injury if not avoided. This may also be used to alert against unsafe practices.

⚠ WARNING: This indicates a potentially hazardous situation that could result in severe injury or death if not avoided.

⚠ DANGER: This indicates an imminently hazardous situation that will result in death if not avoided.

Operating precautions

Franklin Fueling Systems (FFS) equipment is designed to be installed in areas where volatile liquids such as gasoline and diesel fuel are present. Working in such a hazardous environment presents a risk of severe injury or death if you do not follow standard industry practices and the instructions in this manual. Before you work with or install the equipment covered in this manual, or any related equipment, read this entire manual, particularly the following precautions:

IMPORTANT: To help prevent spillage from an underground storage tank, make sure the delivery equipment is well-maintained, that there is a proper connection, and that the fill adaptor is tight. Delivery personnel should inspect delivery elbows and hoses for damage and missing parts.

⚠ CAUTION: Use only original FFS parts. Substituting non-FFS parts could cause the device to fail, which could create a hazardous condition and/or harm the environment.

⚠ WARNING: Follow all codes that govern how you install and service this product and the entire system. Always lock out and tag electrical circuit breakers while installing or servicing this equipment and related equipment. A potentially lethal electrical shock hazard and the possibility of an explosion or fire from a spark can result if the electrical circuit breakers are accidentally turned on while you are installing or servicing this product. Refer to this manual (and documentation for related equipment) for complete installation and safety information.

⚠ WARNING: Before you enter a containment sump, check for the presence of hydrocarbon vapors. Inhaling these vapors can make you dizzy or unconscious, and if ignited, they can explode and cause serious injury or death. Containment sumps are designed to trap hazardous liquid spills and prevent environmental contamination, so they can accumulate dangerous amounts of hydrocarbon vapors. Check the atmosphere in the sump regularly while you are working in it. If vapors reach unsafe levels, exit the sump and ventilate it with fresh air before you resume working. Always have another person standing by for assistance.

⚠ WARNING: Follow all federal, state, and local laws governing the installation of this product and its associated systems. When no other regulations apply, follow NFPA codes 30, 30A, and 70 from the National Fire Protection Association. Failure to follow these codes could result in severe injury, death, serious property damage, and/or environmental contamination.

⚠ WARNING: Always secure the work area from moving vehicles. The equipment in this manual is usually mounted underground, so reduced visibility puts service personnel working on it in danger from moving vehicles that enter the work area. To help prevent this safety hazard, secure the area by using a service truck (or some other vehicle) to block access to the work area.

⚠ WARNING: This product contain a strong magnet. Make sure it does not come into the vicinity of a person with a pacemaker or similar medical aid. The magnetic field associated with this product can adversely affect such devices.

⚠ WARNING: If you are working with drop tubes that have been exposed to fuel or other flammable substances, allow these substances and any vapors to dissipate in a well-ventilated area for an hour before you perform any procedures.

⚠ WARNING: Discharge to ground before putting into service and ensure valve is properly grounded while in service.

⚠ WARNING: When inserting the drop tube/valve assembly into the tank riser pipe, use caution not to forcefully impact the tank riser pipe. When raising/lowering the drop tube/valve assembly while inside the tank riser pipe, do so in a slow, controlled manner.

⚠ WARNING: It is the responsibility of the end user of this product to evaluate each installation location for the following potential ignition sources: lightning, high frequency radio waves, electromagnetic radio waves, ionizing radiation, and ultrasonic sound waves. If any of these potential ignition sources are identified, protective systems/measures shall be implemented.

Specifications

- Model: 708-590 Series
- Type: Class I Automatic Overfill Shutoff Device—Gravity Fill Only
- Size: Fits through 4" schedule 40 (DN 100) pipe
- Flow rate: 25-370 GPM (94-1400 LPM)
- Static pressure rating: 10 PSI (0.7 bar) MAX
- Compatibility: Liquid petroleum fuel blends (E0-E85, B0-B20)

Valve operation

The Franklin Fueling Systems (FFS) model 708-590 Series Overfill Prevention Valve (OPV) is designed with a primary shutoff that activates between 85 and 92% of tank volume, depending on the tank diameter. When the primary shut-off is actuated, the flow through the OPV is limited to less than 8 GPM (30 LPM). A secondary, positive shutoff happens at 95% tank volume if you continue filling. After primary shutoff, you can still drain the delivery hose, but you must be extremely careful and follow these steps:

1. Close the truck bottom loading valve.
2. Wait 5 minutes
3. Partially open the coupler between the delivery hose and the bottom loading valve and allow the hose to drain.

NOTE: Shutoff points are affected by the specific gravity of the stored liquids. These instructions are based on the average performance of all products. The OPV was designed to be only an emergency overfill prevention device.

NOTE: Determine if the underground storage tank has a ball float vent valve. If it does, make sure the nipple portion does not extend more than 3" (76.2 mm) into the tank.

Intentionally Blank

Installation

Installing the OPV

⚠ WARNING: If you are working with drop tubes that have been exposed to fuel or other flammable substances, allow these substances and any vapors to dissipate in a well-ventilated area for an hour before you perform any procedures.

Required equipment

- Tape measure
- Half round file
- Permanent marker
- FFS pipe cutter* or metal saw
- Groove roller tool*
- OPV assembly
- 4" upper drop tube gasket
- Hose clamp
- Warning plate

* Refer to the FFS catalog for ordering information.

Determine drop tube lengths

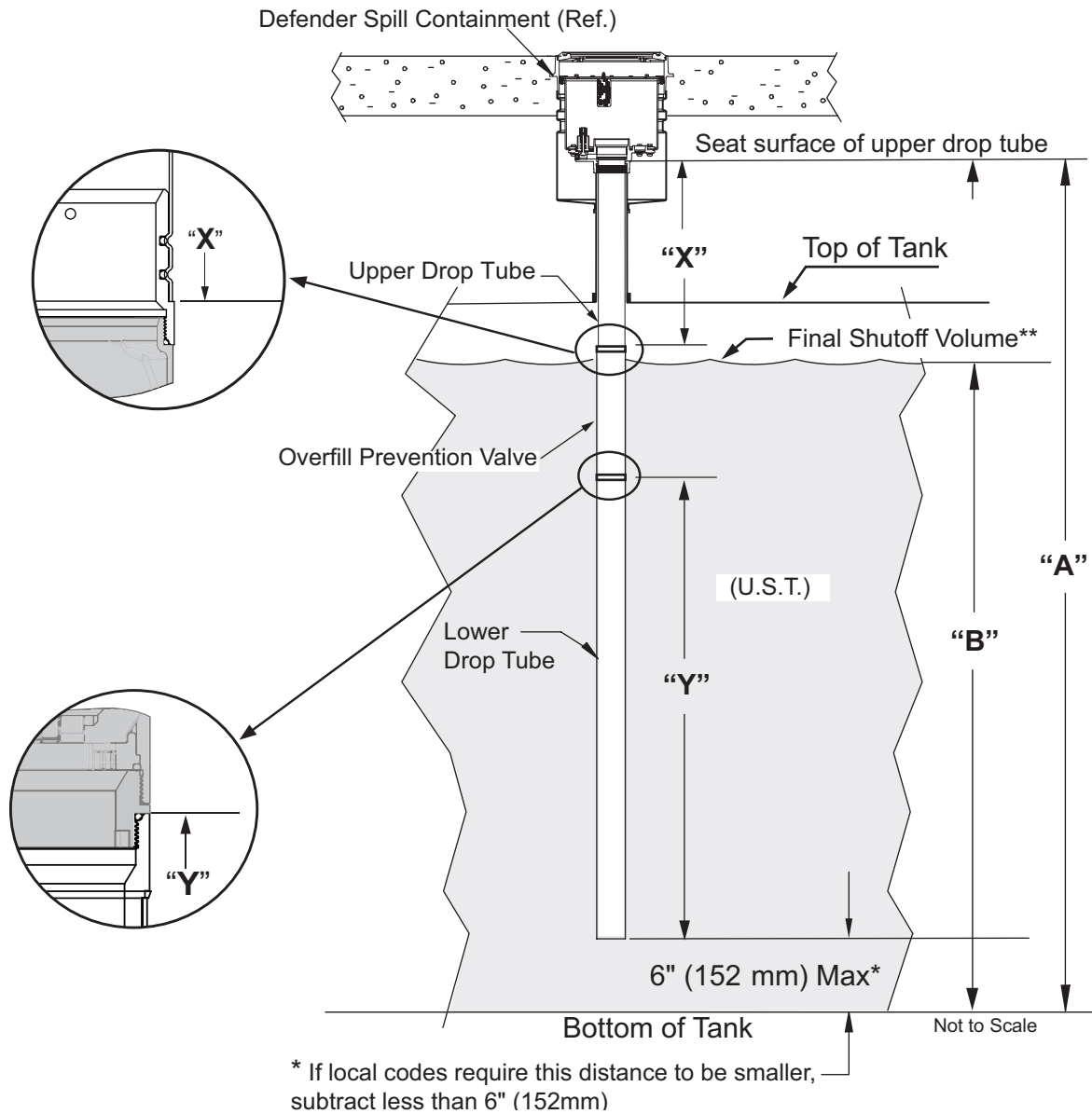

Calculate final shutoff volume

Actual Tank Capacity

Gallons

X (Multiply)

.95 Typically 95%**

= Final shutoff volume (gallons)

= B
Final Shutoff Volume Height

To find Upper Drop Tube length "X"

"A" " Drop tube seat surface to bottom of tank

- (subtract)

"B" " Final shutoff volume height

- (subtract)

2½" (63.5 mm) Position and mounting adjustment

= (equals)

"X"
Upper Drop Tube Length

To find Lower Drop Tube length "Y"

"B" " Final shutoff volume height

- (subtract)

15¾" (400 mm) OPV Length Offset

- (subtract)

6" (152mm) Tank bottom clearance

= (equals)

"Y"
Lower Drop Tube Length

A = The distance from the seat surface of the upper drop tube to the bottom of the underground storage tank. The seat surface will vary depending on the type of installation. See below.

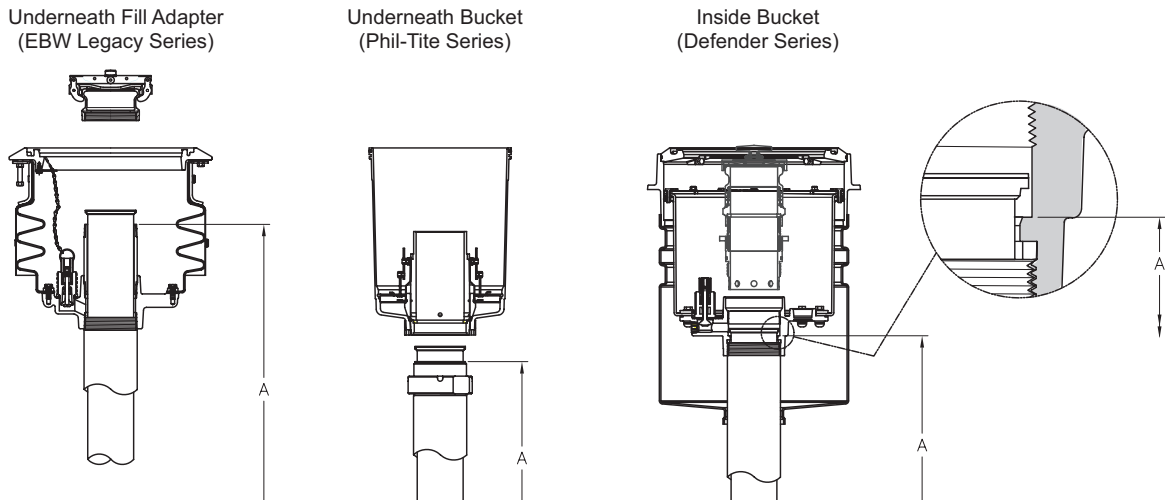

B = FINAL SHUTOFF VOLUME HEIGHT -- According to industry recommended practices, FFS recommends that you set the final shutoff volume to a maximum of 95% of the actual tank capacity. To find the final shutoff volume height, multiply the actual tank capacity (gallons) by the final shutoff volume percentage. (If you are using 95% tank volume, multiply the actual tank capacity by .95.) You then locate the closest volume on the tank chart (provided by the tank manufacturer), and record the corresponding height for "B."

**** NOTE:** To accommodate tank tilt or increased/decreased usage of tank capacity, the final shutoff volume can be adjusted to a value other than 95%, providing it meets all applicable regulatory requirements, and is acceptable to the Authority Having Jurisdiction (AHJ). If the final shutoff volume is not installed at 95%, the installing contractor should document the new volume as intended and include it with the station records as reference for compliance inspections. The installing contractor can do this on the "OPV Installation Record Sheet" or any other applicable station records.

If the final shutoff volume is installed greater than 95%, make sure in all cases that there is at least 250 gallons of ullage volume remaining so that "...none of the fittings located on the top of the tank are exposed to product due to overfilling" according to EPA 40 CFR Part 280.

Mark and cut the drop tubes

1. Mark the upper drop tube with the length X.

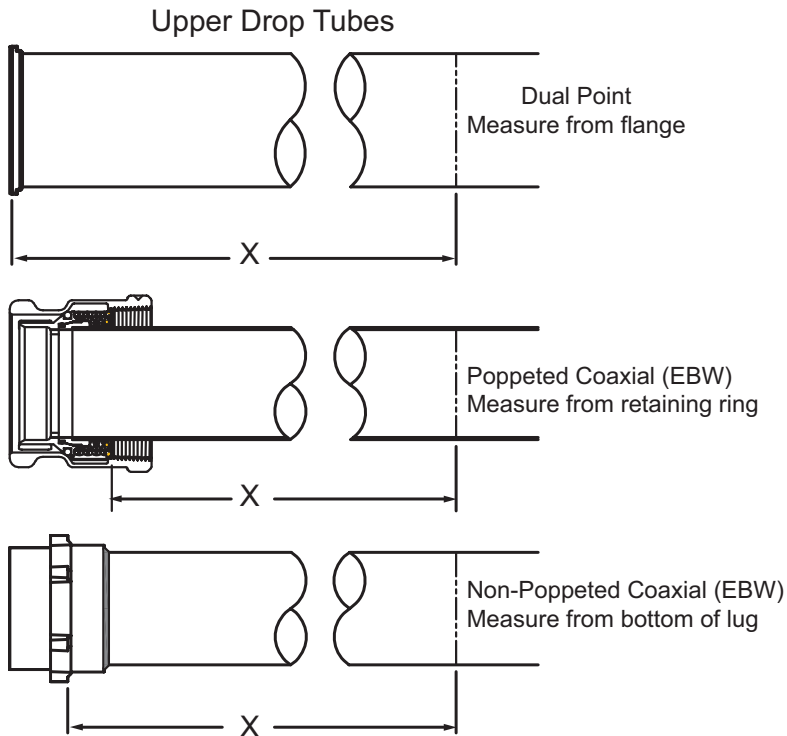

2. Mark the upper lower tube with the length Y.

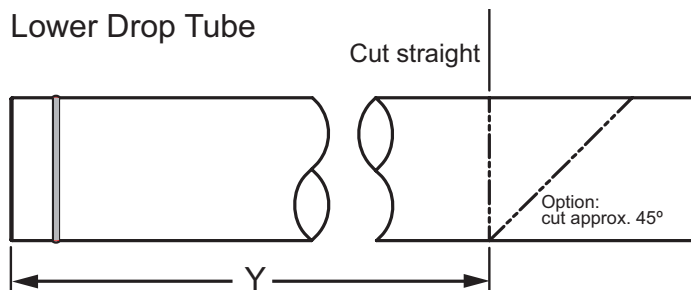

NOTE: FFS recommends the FFS pipe cutter, but if you use a metal saw to cut the drop tube, make sure you cut it as squarely as possible. Use the band clamp included with the warning tag as a guide.

3. Use the FFS pipe cutter to cut the upper drop tube where marked.

NOTE: Tighten the tool handle less than a tenth of a turn for every two times you rotate the tool.

- a. Tighten the blade against the tube just enough to make contact, and then rotate one full turn in one direction.
- b. Rotate one full turn in the opposite direction, and then tighten the cutter approximately one tenth of a turn.
- c. Repeat this process until there is a good scribe line.

IMPORTANT: Do not overtighten the cutter wheel, otherwise the end of the tube could be crimped, which can cause it to be too small to fit the adapter.

4. Use the half-round file to deburr the inside of the upper drop tube, and then test fit the adapter to make sure it fits inside the tube. If the adapter does not fit, continue deburring, and then test fit the adapter again. If the adapter still does not fit, use the information in "Questions and concerns" to contact FFS Technical Support for assistance.
5. Use the FFS pipe cutter to cut the lower drop tube where marked.
Use a metal saw if you have to cut the lower drop tube to a 45 degree angle. Make sure the lowest point of the drop tube does not extend into the minimum clearance specified by the tank manufacturer (or according to local requirements).

Install the upper drop tube adapter

1. Replace the cutting wheel on the Franklin Fueling Systems Pipe Cutter with the Roller Tool.

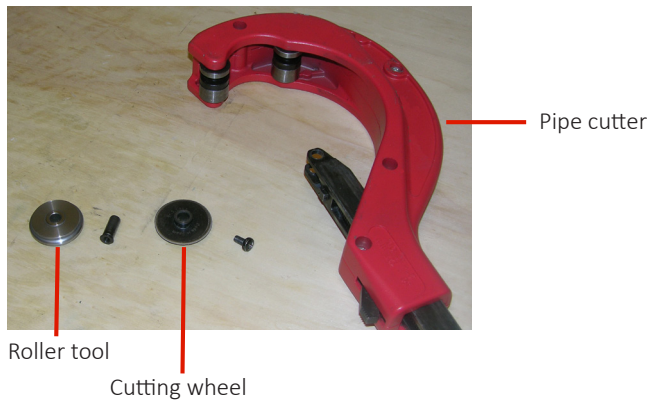

2. Start at the cut end of the upper drop tube, and mark the grooves on the tube.



3. Install the drop tube gasket on the upper drop tube (dual point installation as shown below).



4. Make sure the O-rings are installed on the upper drop tube adapter.

5. Insert the upper drop tube adapter into the cut end of the upper drop tube.
6. Position the roller tool over the mark, and then tighten the roller tool until it makes contact with the upper drop tube.
7. Rotate the roller tool one full turn in one direction, and then rotate it one full turn in the opposite direction.
8. Tighten the roller tool approximately one tenth of a turn, and then repeat the previous step until the groove is complete. The tube is indented enough when the shoulder of the roller tool contacts the tube and creates a witness line or mark.

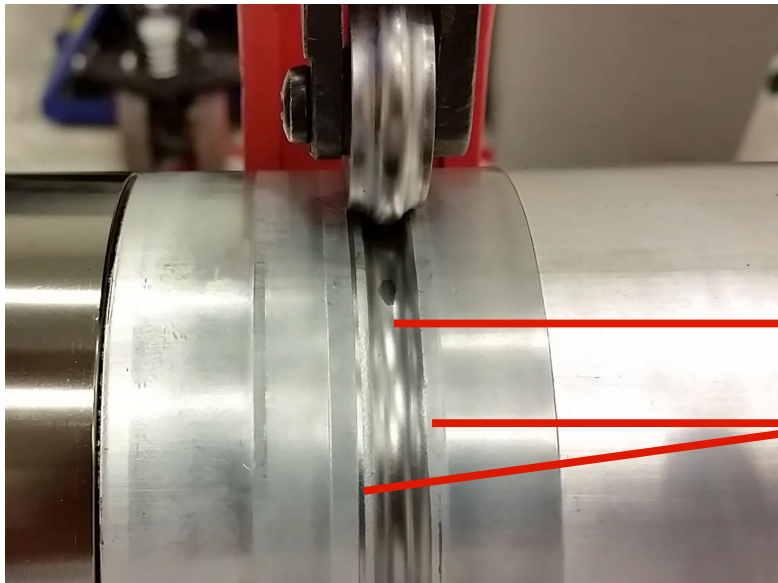

Groove

Witness lines or marks

9. Repeat the previous three steps to create a groove over the second mark.

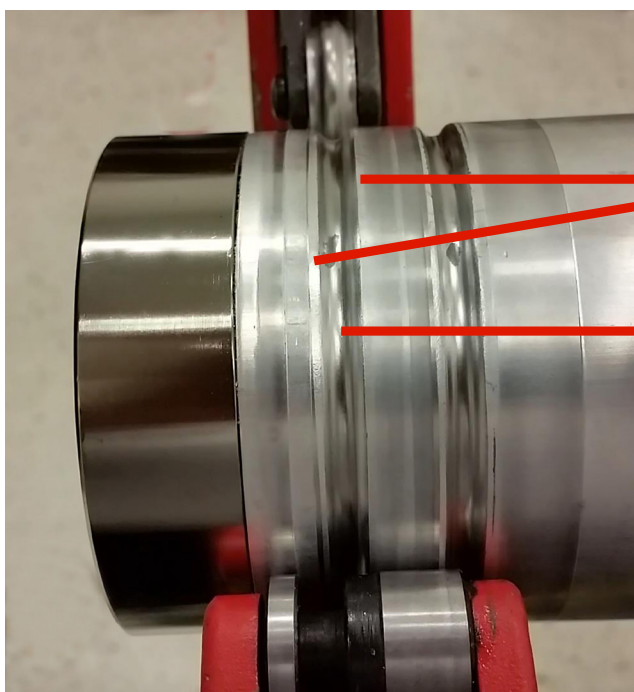

Witness lines or marks

Second groove

Complete the installation

Before you install the OPV, remove any burrs and clean the inside of the tank riser pipe properly. If you do not, the OPV might be damaged or unable to function properly.

NOTE: The upper and lower threads of the drop tube adapters are lubricated at the factory. Do not use pipe sealant. Make sure the O-rings on both ends of the OPV are present and undamaged.

1. Check the float and flapper mechanism by rotating the outer coupler counter-clockwise. Make sure this activates the internal flapper and operates smoothly.

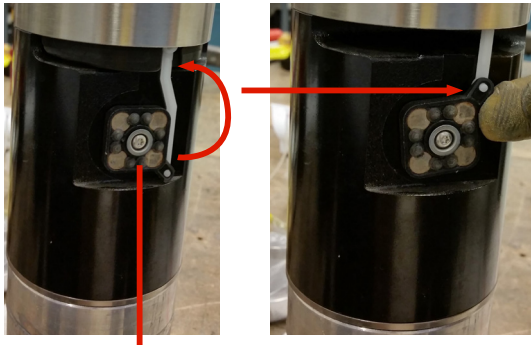

Outer coupler

2. Make sure the drop tube gasket is installed under the upper drop tube flange. (See step 3 of "Install the upper drop tube adapter.")
3. Thread the upper and lower drop tubes onto the OPV, and then use strap wrenches (not pipe wrenches) to tighten the drop tubes. Position one on the upper drop tube, and the other on the lower drop tube. Do not tighten the float shield or valve.



Use wrenches in this area.

Use wrenches in this area.

Do not use wrenches in this area.

4. Ground to earth to discharge any static electricity.
5. Carefully lower the completed OPV assembly into the riser pipe.

Do not drop the assembly or force it down the riser pipe. If it does not fit, clean the riser pipe, and attempt to insert the OPV assembly again. If it still does not fit, the riser pipe may need to be replaced.

6. Reinstall the spill bucket components.
7. Use the stainless steel band clamp to install the warning plate around the 4" (102 mm) riser pipe below the threaded section.



8. Perform the operational inspection procedure.

Operational inspection

Use the FFS remote test tool to inspect the OPV.



1. Assemble the remote test tool with enough extension sections to reach the OPV.
2. Insert the remote test tool into the drop tube. You should feel a "pull" when the magnets are positioned correctly and attract.
3. Slowly raise the remote test tool about 1½" (38 mm). You should see the flapper move into the flow path. If you see the flapper moving back and forth, the OPV is functioning normally.

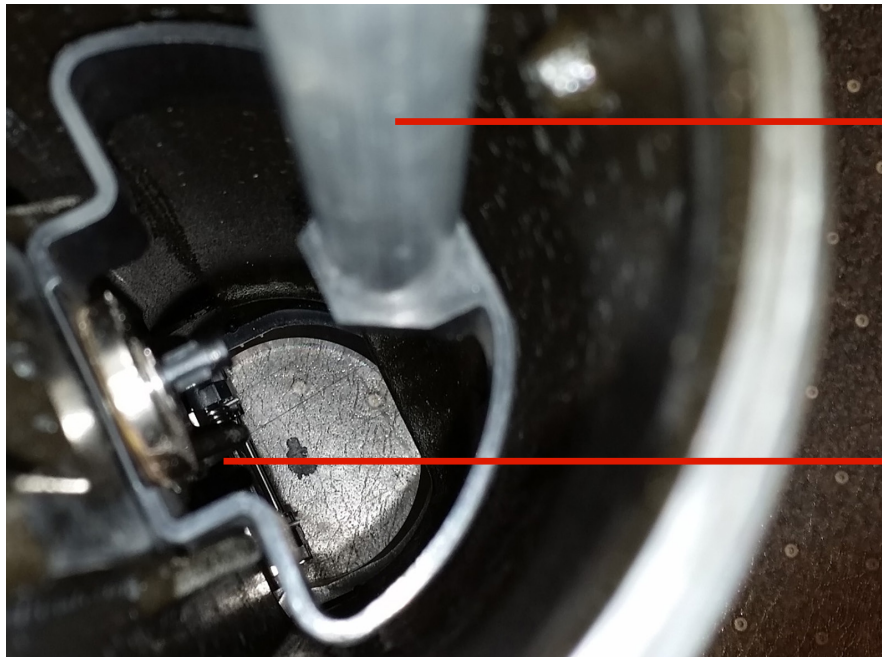

Inspection
tool

Valve flapper in
(not visible)

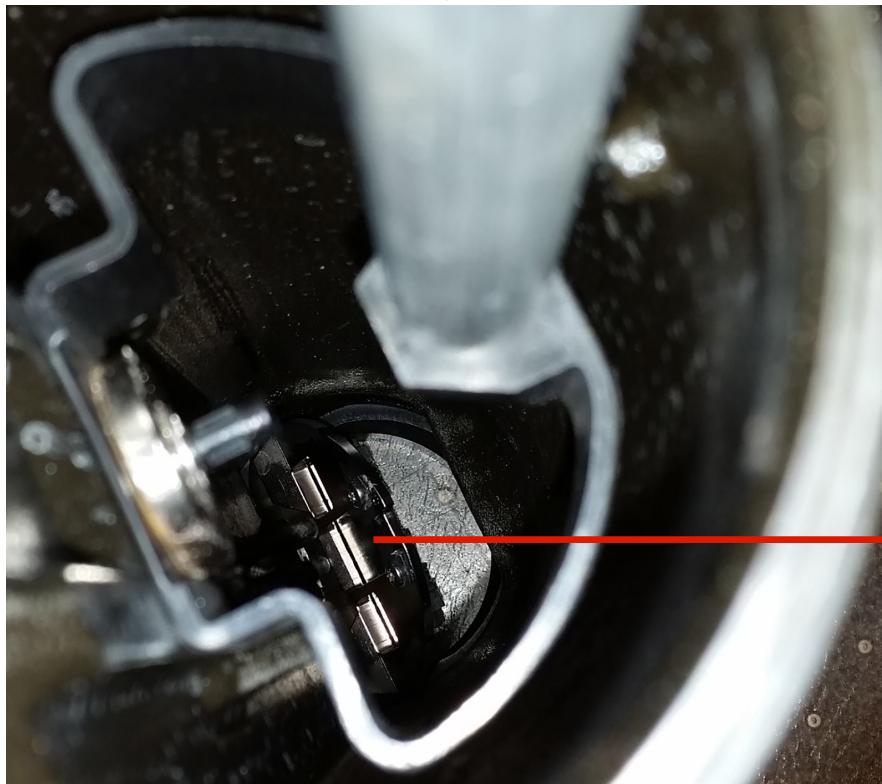

Valve flapper out

NOTE: If required by a local agency, you can push flapper fully closed by inserting a non-sparking stick or rod (no larger than .75" (19 mm) diameter) through the remote test tool opening.

4. Remove the remote test tool by pulling it out of the drop tube. The magnets disengage and the flapper resets automatically.

Intentionally Blank

Maintenance

The OPV has no periodic maintenance requirements, but if you remove the drop tube and OPV assembly from the tank, inspect the drop tube seal for wear or damage. Replace it if necessary.

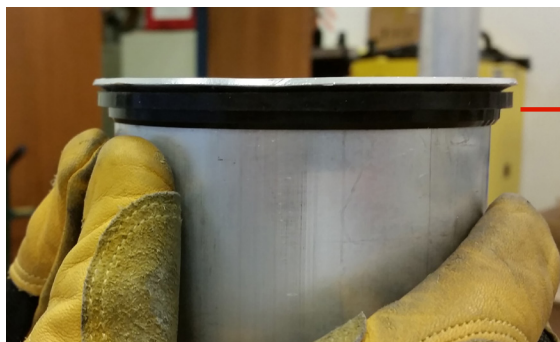

Drop tube gasket
(note orientation)

Also, if you remove the upper or lower drop tube from the OPV, you should replace the O-ring(s).

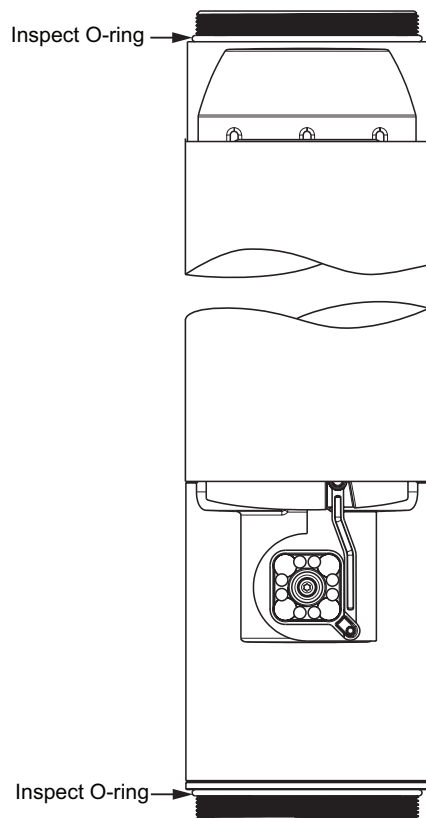

Inspect and verify the final shutoff level

NOTE: When you perform this procedure, do not remove the OPV assembly from the tank.

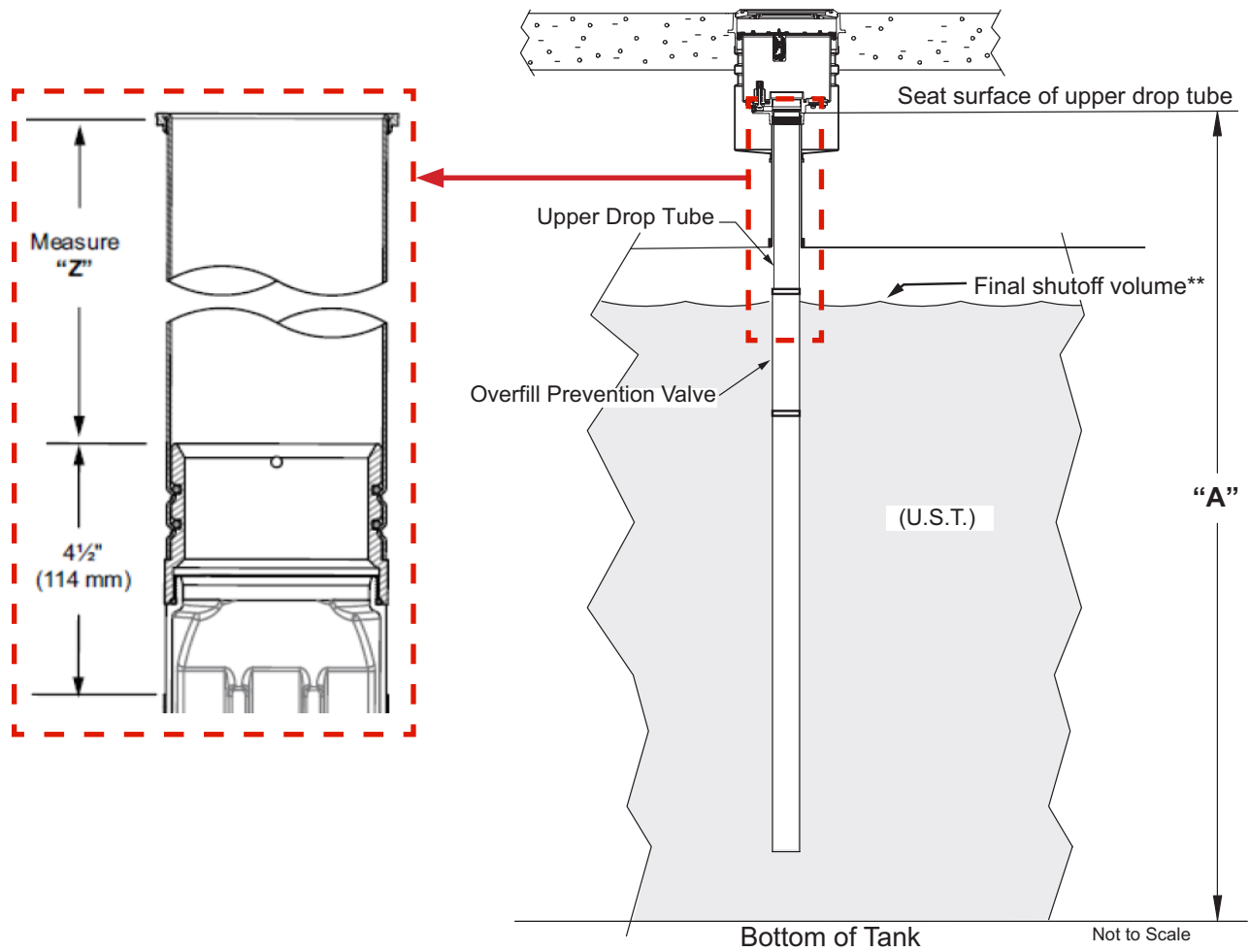

Measure & record "A" and "Z," and then perform the following calculation:

"A" " Drop tube seal surface to the bottom of the tank
 - (subtract)
 "Z" " Upper drop tube flange to the edge of the upper tube adapter
 - (subtract)
 4.5" Reference offset
 = (equals)
 " Final shutoff volume height

Locate the final shutoff volume height on the tank chart provided by the tank manufacturer, and record the closest corresponding volume.

Use the tank chart provided by the tank manufacturer to record and calculate the following:

gal Final shutoff volume
 ÷ (divide by)
 gal Actual tank capacity
 X (multiply by)
 100
 = (equals)
 % Final shutoff volume percentage

If the final shutoff volume percentage is 95% or less, the installation conforms to FFS and industry recommended practices.

gal Actual tank capacity
 - (subtract)
 gal Final shutoff volume
 = (equals)
 gal Ullage volume remaining

The final Shutoff Volume Percentage may be greater than 95% as long as the ullage volume remaining is greater than or equal to 250 gallons, so that "...none of the fittings located on the top of the tank are exposed to product due to overfilling," according to EPA 40 CFR Part 280. The installation must also meet all applicable regulatory requirements, and must be acceptable to the Authority Having Jurisdiction (AHJ).

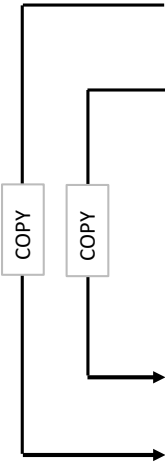

Dimension drawing

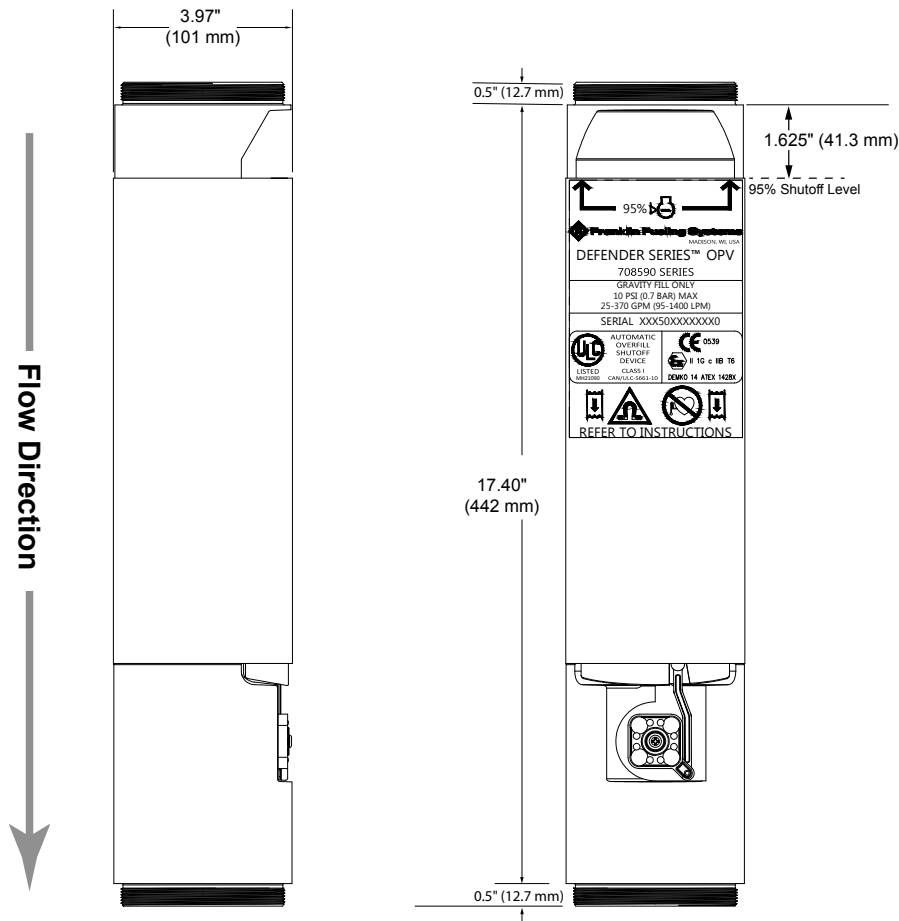

Certification information

ULC	File MH 21090, 1:1	
CARB	VR-101	
ATEX		
Florida	EQ-838	

Production specifications

Construction	
Valve Body	E-Coated Cast Aluminum
Upper Drop Tube	Aluminum or Hard Coat Anodized Aluminum
Lower Drop Tube	Aluminum or Hard Coat Anodized Aluminum
Internal Mechanism	Nickel plated Aluminum, Stainless Steel, Acetal

OPV installation record sheet

Date Installed _____

Valve Serial Number

5 0 _____ 0

Site information

Site # / Description _____

Site Address _____

Site Contact _____

Installing Contractor

Name _____

Company _____

Tank Information

Product Type _____

Underground Tank Manufacturer _____

Tank Full Volume _____

Tank Diameter _____

Tank Chart Available? Yes No

Tank Type Steel Fiberglass

Square Cylinder Dome Ends

Tank have compartments? Yes No

Tank/Drop Tube Measurements

Upper Drop Tube Length (X) _____

Lower Drop Tube Length (Y) _____

Distance from Lower Drop tube to tank bottom _____

Dimensions

A _____

B _____

Final Shutoff Setpoint

_____ Gallons

_____ % Tank Fill

Operational Inspection Procedure Performed

Yes

Initials

Date

No



Franklin Fueling Systems